

The logo features the word "DOR" in white on a dark green rectangular background. To its right is a dark green speaker icon. To the right of the speaker icon, the word "MOUNT" is written in dark green on a white rectangular background with a dark green border. Below this, the tagline "SUSTAINABILITY, SOLUTION & SUPPORT" is written in dark green.

**DOR**  **MOUNT**

*SUSTAINABILITY, SOLUTION & SUPPORT*

## INTRODUCTION

DORMOUNT INDIA is a young and emerging company with experienced professionals having concrete expertise in the field of Clean Rooms.

Dormount is a name that everyone associates with security, trust, and elegance.

With such establishments, we are moving at a tremendous speed towards the next degree in sectors such as Health, Pharmacy, Biotechnology and High-tech which today have an increasing demand for Clean Rooms in India.



We are a company that holds the AN ISO 9001:2015, CE certification, and we specialize in manufacturing cleanroom hardware, coving, and accessories.

## VISION

At DORMOUNT INDIA we understand the importance of maintaining safe and secure access in and around your premises.

DORMOUNT INDIA servicing helps prevent accidents, prolongs the life of the product and helps ensure the safety of users while reducing breakdowns and the accompanying inconvenience.



# MANUFACTURING

Our technical process and advanced machinery are the key factors of our innovative drive as we continue to pioneer the way we offer solutions, the way we deliver value, and the way we maintain our quality assurance.



The raw materials are sourced only from the best suppliers and they all undergo rigorous testing at the early cycle for impeccable product quality. The Company uses a 4 Stage Integrated baking system to ensure the highest reliability standards and long-lasting life in product finishing.

## SS 304 D TYPE HANDLE WITH BRASS BUSH

Stable handle to open doors of opportunities with glaring stainless steel finish

### Key Features

- 304 Grade Stainless Steel.
- Brass Bush for holding fixture
- Anti- Corrosive.
- Excellent Finishing
- Cost-effective
- Zero Maintenance.
- For Metal Doors.



### MODELS & SPECIFICATIONS

- |            |  |
|------------|--|
| • DSH 3019 | Single Side, length 300mm, Dia 19 mm.  |
| • DBH 3019 | Back to Back, length 300mm, Dia 19 mm. |
| • DSH 2519 | Single Side, length 250mm, Dia 19 mm.  |
| • DBH 2519 | Back to Back, length 250mm, Dia 19 mm. |



## SS 304 BALL BEARING HINGES

High Performance Hinge for use on flush - closing doors in severe duty situations.

### Key Features

- For metal doors.
- Non handed.
- The door opening angle is 180 degrees.
- The non-removable welded end provides extra security. Easy to install.
- More durable and less noisy than standard hinges.
- Two Ball Bearing with Five Knuckles
- Non-Magnetic hinges and bearing.
- Certified with BS EN 1634 and CE.
- Fire-rated with 120 minutes
- Stainless steel Philip Head Machined screws.
- Stainless steel chrome finish.
- 10,00,000 cycles tested.
- Specially designed for heavy duties doors permanently lubricated bearings exact all vertical load and reduce the friction that makes the smooth movement of the door.

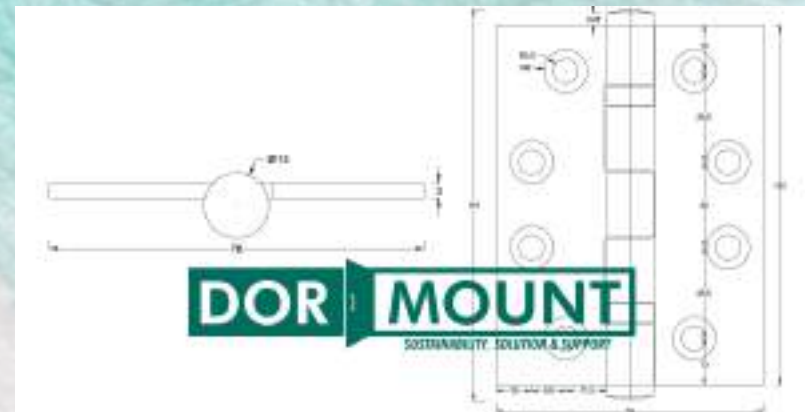

### MODELS & SPECIFICATIONS

- DFH 4335      2 Ball Bearing , L -4" , W-3" , T-3mm , M5 Screw.
- DFH 4336      2 Ball Bearing , L -4" , W-3" , T-3mm , M6 Screw.

## SS 304 DEAD LOCK ( DDL DL100 )

Extra Secure Lock system for multi - facilitated units.

### Key Features & Specification

- DORMOUNT Dead Locks provide the ideal answer for every application including commercial high usage doors such as education facilities, hospitals, military installations, corrective service facilities, Hotels, Pharmaceuticals, Clubs, Office Buildings and residential applications.
- Heavy-duty construction with GI powder-coated body, faceplate, strike and deadbolt are of SS304 grade.
- A full range of functions including privacy, passage, vestibule, escape, anti-lockout etc. all available from the one primary lock body.
- Dead latching and kick-off are standard on all functions.
- Supplied complete with all fixing and suitable for the door.
- Suitable for moderate security applications.
- 138 mm cram height and 60mm backset standard.
- This product exceeds Indian Lock Standards for strength and durability.
- Stainless steel chrome finish.
- 1,00,000 cycles tested.

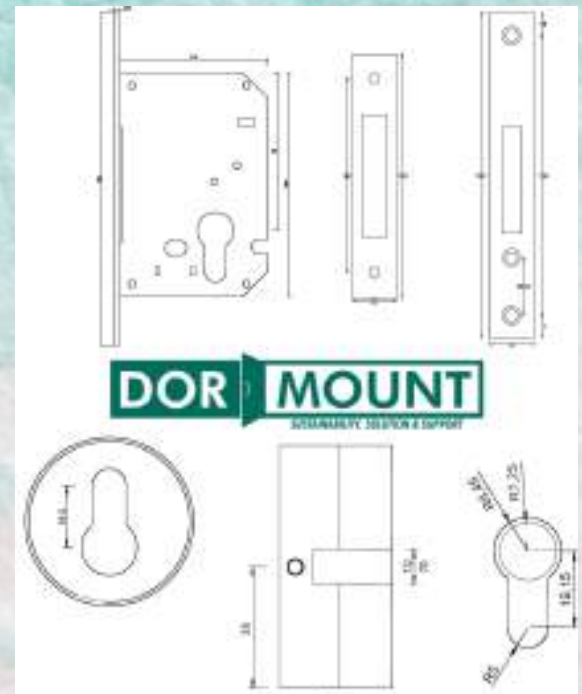

## SS 304 DEAD LOCK( DDL DL150 )

Extra Secure Lock system for multi - facilitated units.

### Key Features & Specification

- DORMOUNT Dead Locks provide the ideal answer for every application including commercial high usage doors such as education facilities, hospitals, military installations, corrective service facilities, Hotels, Pharmaceuticals, Clubs, Office Buildings and residential applications.
- Heavy-duty construction with GI powder-coated body, faceplate, strike and deadbolt are of SS304 grade.
- A full range of functions including privacy, passage, vestibule, escape, anti-lockout etc. all available from the one primary lock body.
- Dead latching and kick-off are standard on all functions.
- Supplied complete with all fixing and suitable for the door.
- Suitable for moderate security applications.
- 160 mm cram height and 55mm backset standard
- This product exceeds Indian Lock Standards for strength and durability.
- Stainless steel chrome finish.
- 1,00,000 cycles tested.

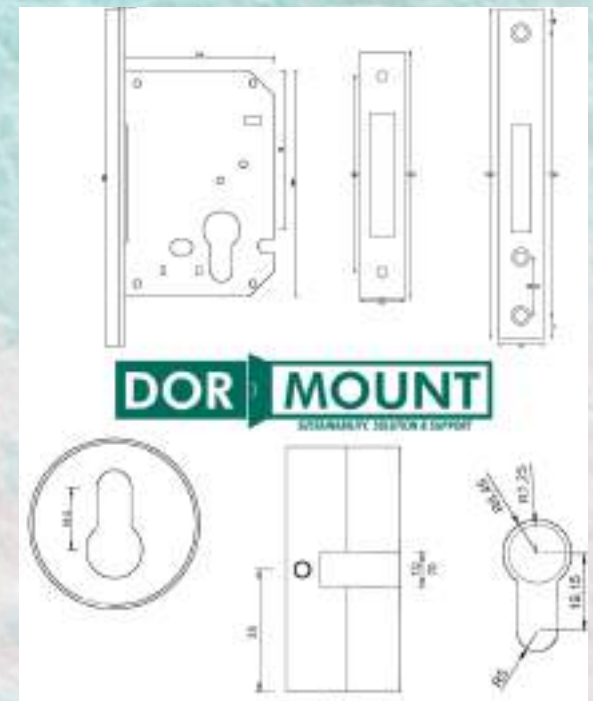

## 70 mm ULTRA KEYS BRASS CYLINDER BOTH SIDE KEYS ( DLC 70 )

Heart of Locking System with best performance and accuracy.

### Key Features & Specification

- 12 pin Euro profile cylinder is a convenient everyday locking solution.
- High-security ultra key mechanism.
- Both cylinder and keys are of pure brass.
- The euro profile cylinders are literally the key to locking system security on both external and internal doors.
- High-quality, matched materials ensure excellent corrosion and wear resistance.
- We provide precise, reliable functionality and durability.
- For sophisticated solutions in a comprehensive cylinder portfolio – with the right level of protection aligned to individual requirements and strong performance throughout
- These are Anti Drill, Anti-pick and Anti bump.
- Comes with both side keys with 3 keys.
- A - 70 , B - 35 , C - 35 in mm.
- 5,00,000 cycles tested.

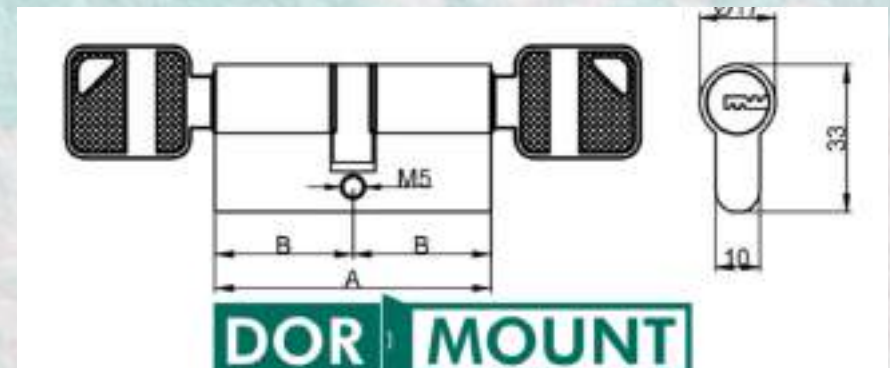

## 70 mm ULTRA KEYS BRASS CYLINDER ONE SIDE KNOB ( DKC 70 )

Heart of Locking System with best performance and accuracy.

### Key Features & Specification

- 6 pin plus 1 pin Euro profile cylinder is a convenient everyday locking solution.
- High-security ultra key mechanism.
- Both cylinder and keys are of pure brass.
- The euro profile cylinders are literally the key to locking system security on both external and internal doors.
- High-quality, matched materials ensure excellent corrosion and wear resistance.
- We provide precise, reliable functionality and durability.
- For sophisticated solutions in a comprehensive cylinder portfolio – with the right level of protection aligned to individual requirements and strong performance throughout
- These are Anti Drill, Anti-pick and Anti bump.
- Comes with one side key and one side knob with 3 keys.
- A - 70 , B - 35 , C - 35 in mm.
- 5,00,000 cycles tested.

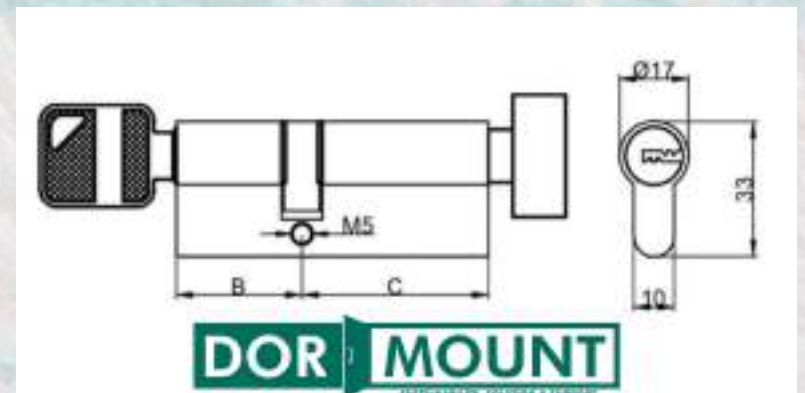

## HEAVY DUTY DOOR CLOSER ( DDC 90 )

Swiftly precisely with high performance mechanism.

### Key Features & Specification

- The body is manufactured by pure aluminium die-cast alloy machined to extreme accuracy.
- Compact design for the non-handed application.
- Rack and pinion mechanism for better efficiency.
- Stable hydraulic fluid for all climate conditions.
- One model for all standard doors, Door widths up to 1100 mm.
- Minimal closer body projection.
- Selectable closing force according to the need of the site.
- With weight carry capacity from 80 - 100 Kg.
- The arm to hold the door closer is advanced with a self-locking mechanism.
- Tested upto 1,00,000 cycles in -10 to 70 degree celius temp range.

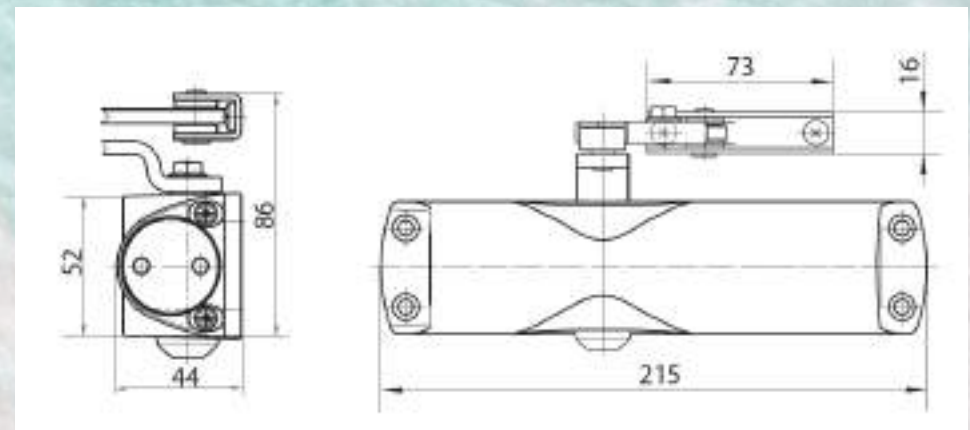

## HEAVY DUTY DOOR CLOSER ( DDC 70 )

Swiftly with high performance mechanism.

### Key Features & Specification

- The body is manufactured by pure aluminium die-cast alloy machined to extreme accuracy.
- Compact design for the non-handed application.
- Rack and pinion mechanism for better efficiency.
- Stable hydraulic fluid for all climate conditions.
- One model for all standard doors, Door widths up to 1100 mm.
- Minimal closer body projection.
- Selectable closing force according to the need of the site.
- With weight carry capacity up to 70 Kg.
- The arm to hold the door closer is standard with a screw-locking mechanism.
- Tested upto 1,00,000 cycles in -10 to 70 degree celius temp range.

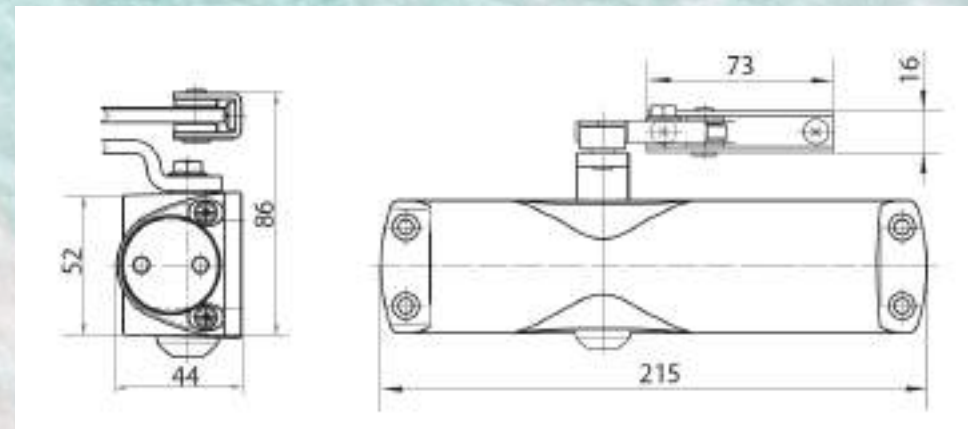

## SS304 FLUSH BOLT ( DFB 300 )

The solution for double-panel door systems.

### Key Features & Specification

- DORMOUNT flush bolts allow the automatic locking and unlocking of the passive door panel of a double-panel system.
- Users may unlock and open the active panel with the flick of a wrist, which simultaneously unlocks the passive panel allowing it to be opened.
- Reliable function and low mounting effort.
- The adjustable and flexibly-mounted spindle only requires a milled slot for the latch keeper and a hole for the lock bolt - so there is no need to rip up the door panel or remove any part of it.
- Its two-piece design allows easy compensation of mounting tolerances and provides the door system with maximum stability.
- Minimal closer body projection.
- Stainless steel forend.
- Cranked latch.
- Split, adjustable spindle.
- Twice flexible mounting.
- Adjustable latch bolt, incl. adjustable retainer bushing.
- Rod size is 150 mm
- 1,00,000 cycles tested.

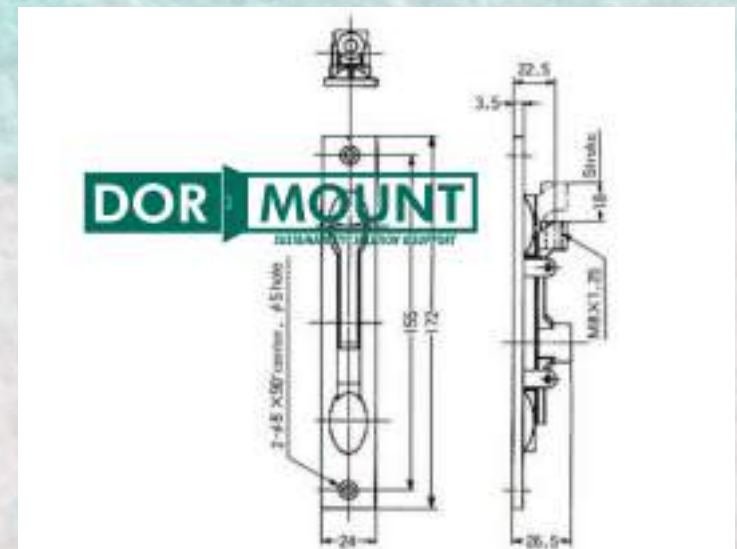

## SS304 FLUSH BOLT ( DFB 450 )

The solution for double-panel door systems.

### Key Features & Specification

- DORMOUNT flush bolts allow the automatic locking and unlocking of the passive door panel of a double-panel system.
- Users may unlock and open the active panel with the flick of a wrist, which simultaneously unlocks the passive panel allowing it to be opened.
- Reliable function and low mounting effort.
- The adjustable and flexibly-mounted spindle only requires a milled slot for the latch keeper and a hole for the lock bolt - so there is no need to rip up the door panel or remove any part of it.
- Its two-piece design allows easy compensation of mounting tolerances and provides the door system with maximum stability.
- Minimal closer body projection.
- Stainless steel forend.
- Cranked latch.
- Split, adjustable spindle.
- Twice flexible mounting.
- Adjustable latch bolt, incl. adjustable retainer bushing.
- Rod size is 300 mm
- 1,00,000 cycles tested.

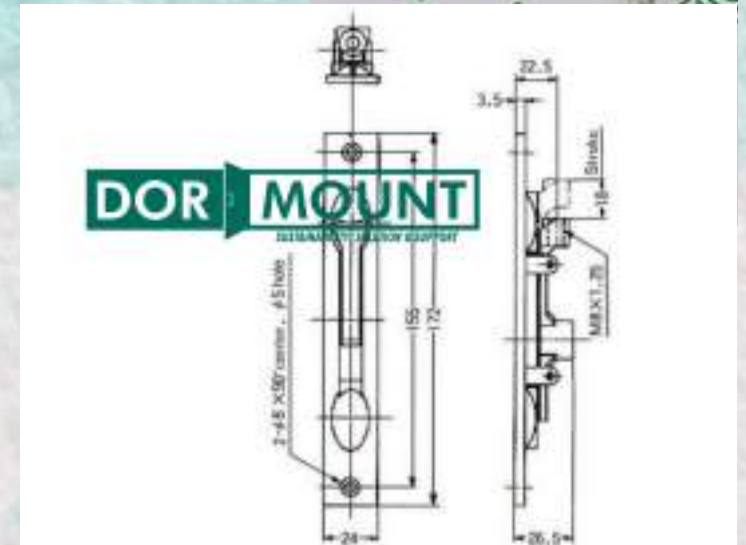

## DIE CASTED FLUSH BOLT ( DFB 200 )

The solution for double-panel door systems.

### Key Features & Specification

- DORMOUNT flush bolts allow the automatic locking and unlocking of the passive door panel of a double-panel system.
- Users may unlock and open the active panel with the flick of a wrist, which simultaneously unlocks the passive panel allowing it to be opened.
- Reliable function and low mounting effort.
- The adjustable and flexibly-mounted spindle only requires a milled slot for the latch keeper and a hole for the lock bolt - so there is no need to rip up the door panel or remove any part of it.
- Its two-piece design allows easy compensation of mounting tolerances and provides the door system with maximum stability.
- Minimal closer body projection.
- Aluminium die-cast forend.
- Aluminium die-cast Cranked latch.
- Split, adjustable spindle.
- Twice flexible mounting.
- Adjustable latch bolt, incl. adjustable retainer bushing.
- Rod size is 150 mm
- 1,00,000 cycles tested.

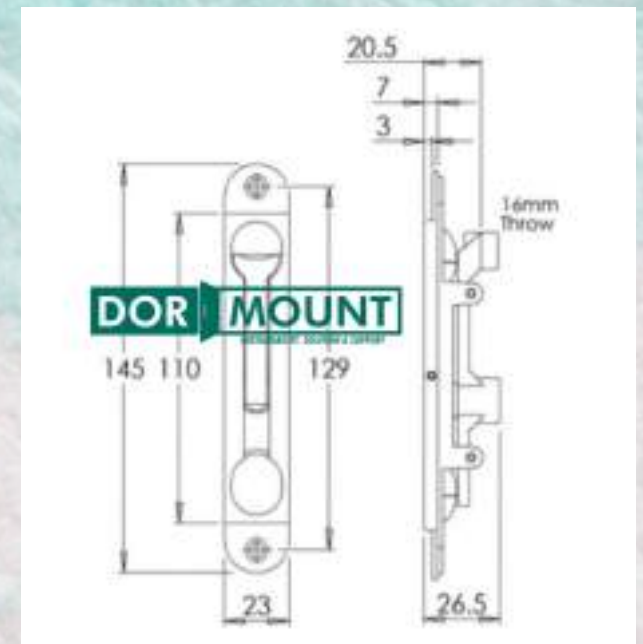

## PURE GRADE ALUMINIUM COVING WITH BACKING ( DAC )

The solutions to clean room that make it more elegant.

### Key Features & Specification

- DORMOUNT Aluminum coving is an extruded product.
- Alu, coving provides a smooth hygienic contact seal at the transition of wall-to-wall, wall-to-ceiling and wall-to-floor, negating the need for silicon as per RAL.
- MOC : Pure aluminium ingot, i.e. Aluminium 6063.
- Components: Aluminium coving face, aluminium backing angle.
- Reliable function and low mounting effort with flush fitting.
- Quick and hassle-free installation.
- No-maintenance.
- Cost-effective.
- Replace within minutes without any tools.
- Powder-coated in any RAL colour & anodized.
- Sizes available radius R50 mm & R70 mm.

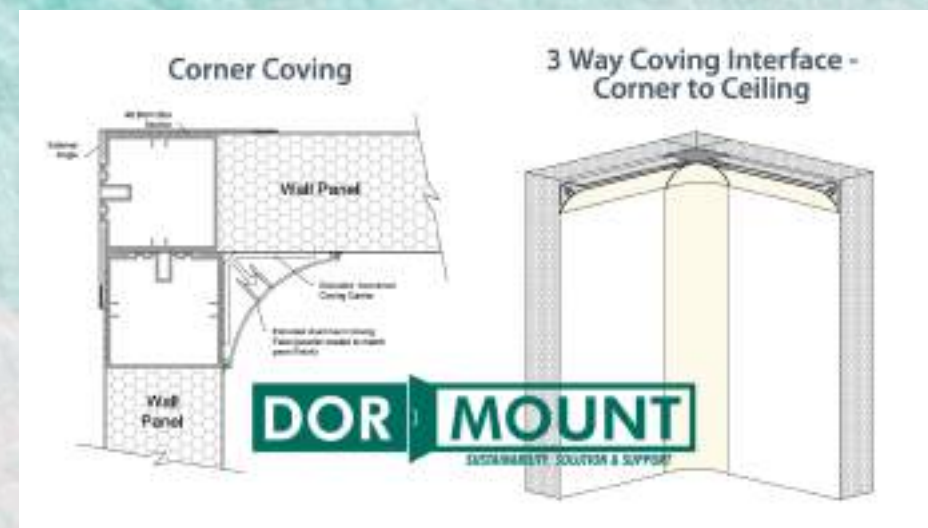
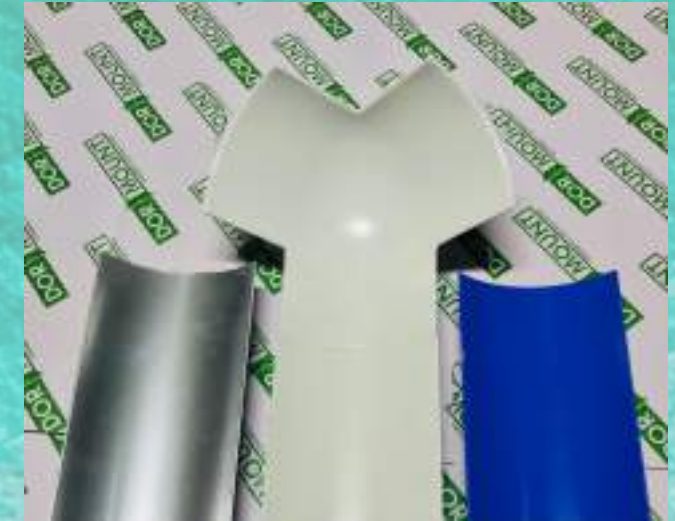

## DIE-CASTED ALUMINIUM 3 D CORNER ( DAC D3 )

The solutions to clean room that add re fineness.

### Key Features & Specification

- DORMOUNT Aluminum 3 D Corner is a die-casted product.
- 3 D Corner provides a smooth hygienic contact seal at the transition of coving where three coving meet together at 90 degree
- Reliable function and low mounting effort with flush fitting.
- MOC : Pure aluminium ingot, i.e. Aluminium 6063.
- Quick and hassle-free flush fit installation.
- No maintenance, Cost-effective.
- Replace within minutes without any tools.
- Powder-coated in any RAL colour & anodized.
- Sizes available radius R50 mm & R70 mm.

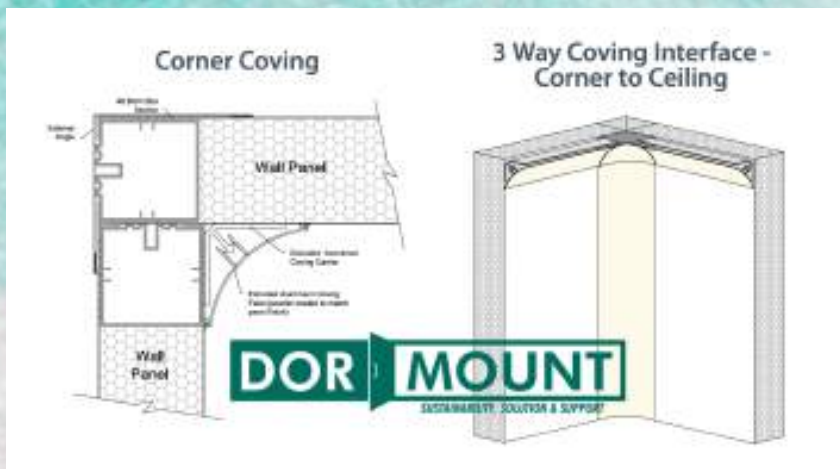

## DIE-CASTED ALUMINIUM 2 D CORNER ( DAC D2 )

The solutions to clean room that add re fineness.

### Key Features & Specification

- DORMOUNT Aluminum 2 D Corner is a die-casted product.
- 2 D Corner provides a smooth hygienic contact seal at the transition of coving where two coving meet horizontal.
- Reliable function and low mounting effort with flush fitting.
- MOC : Pure aluminium ingot, i.e. Aluminium 6063.
- Quick and hassle-free flush fit installation.
- No maintenance, Cost-effective.
- Replace within minutes without any tools.
- Powder-coated in any RAL colour & anodized.
- Sizes available radius R50 mm & R70 mm.



## PURE GRADE EXTERNAL ALUMINIUM COVING ( DEAC 50 )

The solutions to clean room that make it more elegant.

### Key Features & Specification

- DORMOUNT Aluminum coving is an extruded product.
- Alu, coving provides a smooth hygienic contact seal at the transition of wall-to-wall, negating the need for silicon as per RAL.
- Components: Aluminium coving face fixed at 90 degrees with two wall panels.
- Reliable function and low mounting effort with flush fitting.
- MOC : Pure aluminium ingot, i.e. Aluminium 6063.
- Quick and hassle-free flush fit installation.
- No-maintenance.
- Cost-effective.
- Replace within minutes without any tools.
- Powder-coated in any RAL colour & anodized.
- Sizes available for 50 mm wall panel.

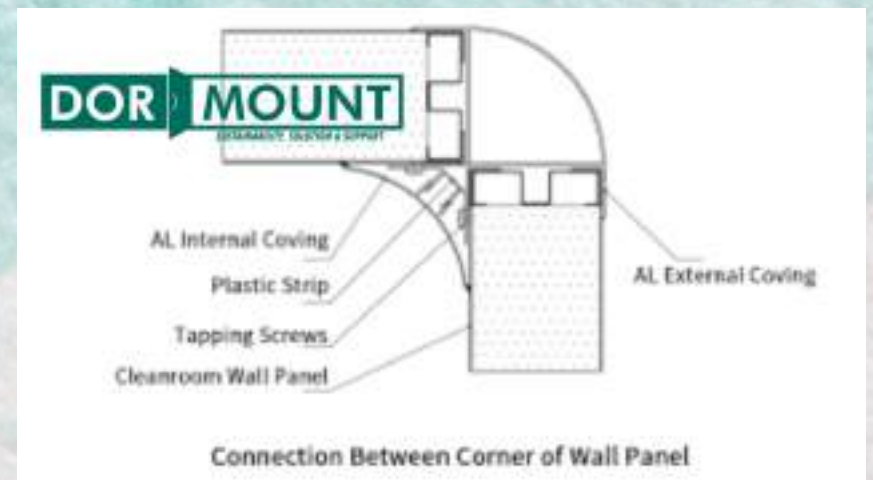
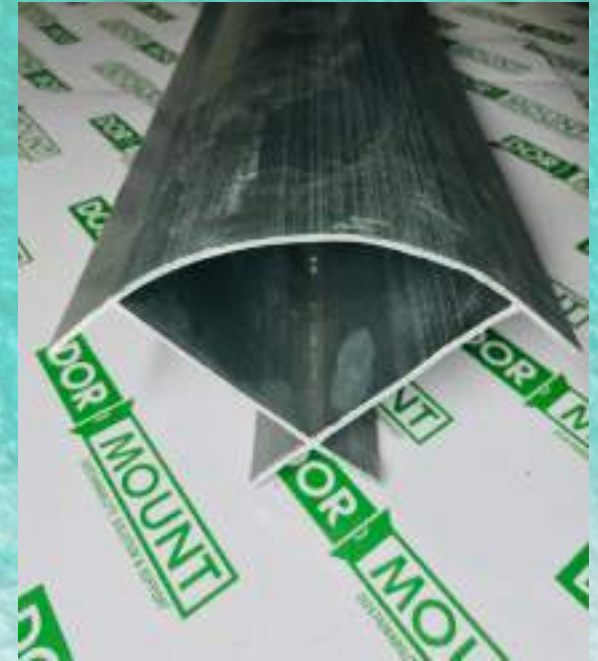

## DIE CASTED ALUMINIUM EXTERNAL 2 D CORNER ( DEAC D2 )

The solutions to clean room that add re fineness.

### Key Features & Specification

- DORMOUNT Aluminum external 2 D Corner is a die-casted product.
- 2 D Corner provides a smooth hygienic contact seal at the transition of coving where external vertical coving meets two horizontal covings altogether.
- Reliable function and low mounting effort with flush fitting.
- MOC : Pure aluminium ingot, i.e. Aluminium 6063.
- Quick and hassle-free flush fit installation.
- No maintenance, Cost-effective.
- Replace within minutes without any tools.
- Powder-coated in any RAL colour & anodized.
- Sizes available 50 mm external coving.

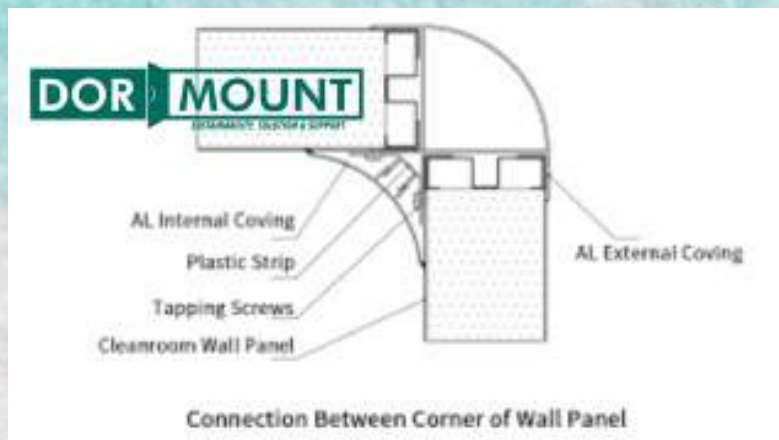

## PURE GRADE PVC COVING WITH BACKING ( DPC )

The solutions to clean room that make it more elegant.

### Key Features & Specification

- DORMOUNT PVC coving is an extruded product.
- PVC, coving provides a smooth hygienic contact seal at the transition of wall-to-wall, wall-to-ceiling and wall-to-floor, negating the need for silicon as per colour.
- Components: PVC coving face, PVC backing angle with soft edge
- Reliable function and low mounting effort with flush fitting.
- MOC: Pure PVC with part of silicon.
- Quick and hassle-free installation.
- No-maintenance.
- Cost-effective.
- Replace within minutes without any tools.
- Off-White, Milky white and grey in any colour.
- Sizes available 65 mm & 100 mm.



## AUTOMATIC DROP SEAL DDSIII 10.0

A spring-loaded mechanism, ensures easy door operation & effective sealing when closed.

### Key Features & Specification

- DORMOUNT drop seals are Mortised, automatic 'flat back' seal to suit installation to metal door.
- Spring-loaded mechanism lifts the seal clear of the floor as soon as the door is opened by a few millimeters.
- Self-leveling on uneven floors, seal height can be adjusted independently of fixing screws.
- MOC : Pure aluminium ingot, i.e. Aluminium 6063.
- Gasket are silicon food grade as per WHO, USFDA, CGMP, NABH .
- Quick and hassle free installation.
- No-maintenance .
- Cost effective.
- Tested upto 10,00,000 cycles.

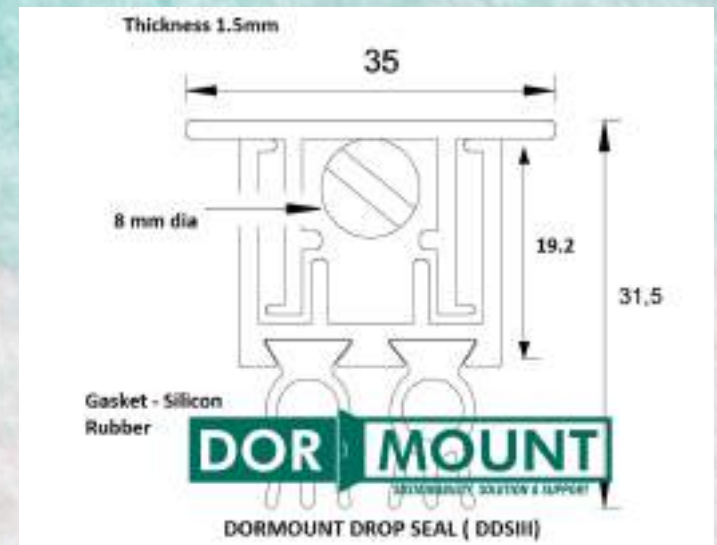

## PERIMETER SEAL ( DPS )

A self adhesive seal , ensures easy door operation & effective sealing when closed.

### Key Features & Specification

- DORMOUNT perimeter seals are EPDM with self-adhesive backing.
- EPDM sealing strip, smooth surface details, good elasticity and compression deformation.
- Excellent weather ability, anti-ageing, anti-ozone anti-wearing and chemical resistance.
- excellent anti UV performance, heat insulation, and outstanding acoustic performance.
- Wide operating range under extreme cold and warm weather.
- Seals are EPDM food grades as per WHO, USFDA, CGMP, and NABH.
- Quick and hassle-free installation.
- No-maintenance.
- Cost-effective.

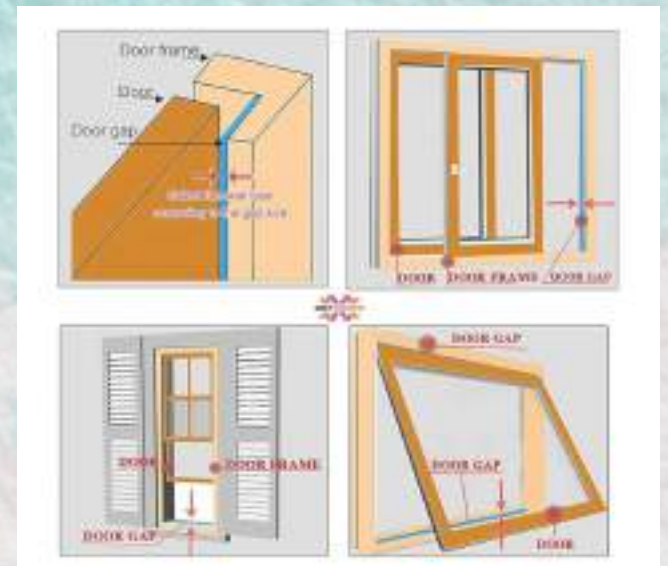

## EXTERNAL AUTOMATIC DROP SEAL DDSIV 10.0

A spring-loaded mechanism, ensures easy door operation & effective sealing when closed.

### Key Features & Specification

- DORMOUNT semi-mortised automatic drop seal with a high efficiency mechanism which lifts the seal clear of the floor as soon as the door is opened by a few millimetres; resulting in lower door operating forces.
- DDSIV with a curved cover plate for enhanced aesthetics: surface mounted only.
- Self-leveling on uneven floors, seal height can be adjusted independently of fixing screws.
- MOC : Pure aluminium ingot, i.e. Aluminium 6063 .
- Gasket are silicon food grade as per WHO, USFDA, CGMP, NABH .
- Sound reduction.
- Protect against smoke.
- Quick and hassle free installation.
- No-maintenance .
- Cost effective.
- Tested upto 10,00,000 cycles.

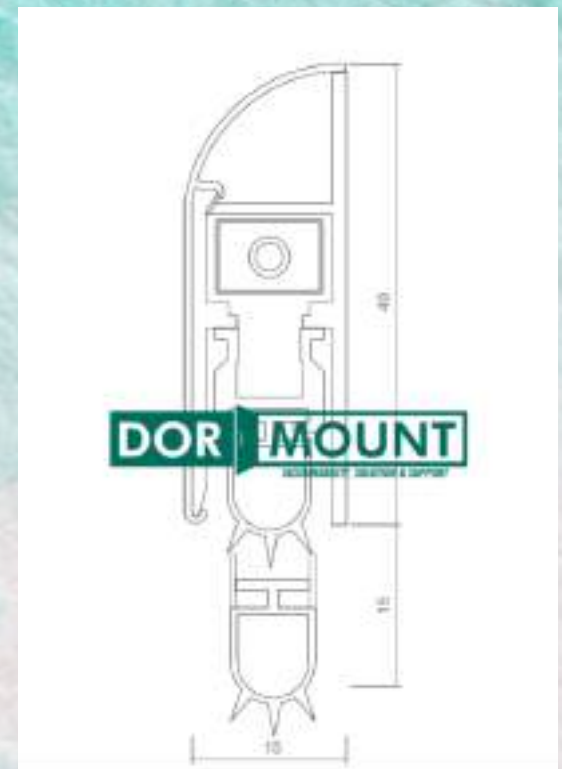

# CERTIFICATION



**MSME**



**BS EN 1634**



**CE**



**ISO 9001:2015**

Looking for more than just a product ? Begin with us.  
***as our Motto's 3 S's  
SUSTAINIBLITY, SOLUTION &  
SUPPORT say: We provide  
sustainable product which gives  
solution to your cleanroom with  
best service and support.***

For more information, visit our website!

**[www.dormountindia.com](http://www.dormountindia.com)**

**[www.dormountindia.in](http://www.dormountindia.in)**

You may contact us on email:

**[info@dormountindia.com](mailto:info@dormountindia.com)**

